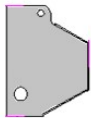

SG Audio Visual Product Specification

SGHEH500	232" Premium Intelligent Large Electric screen for Mixed Presentations
-----------------	---

General	
Recommended Use	Perfect for larger conference rooms and halls in conjunction with any WUXGA or 4k WQUXGA projector. The 16:10 format is the multipurpose standard and designed to match with the native aspect ratio of most high lumen installation projectors.
Compatibility	Suitable for WUXGA and 4K projection. Not suitable for ultrashort projectors.

Screen Surface	
Material	Matte White Premium Fiberglass with lightproof black backing. 1.1 gain with 100 degree viewing angle.
Overall Surface	W: 500cms H: 312.5cms or 361cm with max black leader Diag: 186 in
Viewable Surface	W: 488cms H: 305cms Diag: 181 in
Black Leader	50 cms top adjustable via limit control
Border	6cms left and 6cms right

Housing	
Material	Aluminium alloy (large case)
Colour	White
Housing Profile	
Housing Dimensions	W: 9.6cms H: 12.9cms L: 516.6 cms
Weight	92kg Gross / 75kgs Net

Electrical and Control	
Wireless Remote	RF remote included.
Wireless Wall Switch	RF wall switch included
Wifi	Standard. Download app with voice control options.
Low voltage Control	Standard. Control cable is optional
Motor	Premium tube motor
Motor location	Left Hand side
Power	220V~240V, 50Hz, Power cord 2m (Removable)

Warranty	
Standard Warranty	2 years
Extended warranty	1 additional year available



SGHEH500 232" 16:10 format HE Series Large
Commercial Grade Electric Projector Screen (5.0m * 3.12m)

HE Series Large Premium Intelligent Electric Screens

SG Audio Visual Large HE Series intelligent projection screens are larger commercial grade Electric screens for wall or ceiling mounting. They feature a premium fiberglass matte white surface with lightproof black backing. The fiberglass surface is more rigid and minimises stretching. The screens also feature a hexagonal aluminium alloy housing, long 50cm black leader (adjustable), intelligent control system with wireless and wi-fi control and premium tube motor. The system is supplied with remote control, wireless wall-switch and power cable and supports wi-fi control via a mobile phone app.

Projection Surface

The matte white fiberglass surface provides a good 1.1 gain and wide 165 degree viewing angle. The black backing ensures that it is lightproof.

This surface is designed for UHD/4K projection but will also perform well with WUXGA/1080p projection.

The 50cm long black leader on these screens may be adjusted to ensure that the viewable white surface is at a comfortable viewing height.

Screen Dimensions

This 232" HE Series Large 16:10 screen has a 5.0m wide white surface with lightproof black backing with an overall drop of up to 3.61m including the 50cm black leader. After allowing for the 6cm black border the image size supported is approximately 4.88m * 3.05m. The slimline housing is only 9.6cms and 12.9cms high and the screen has an overall length of 5.16m.

We would normally recommend this screen for business or mixed presentations in a small hall or conference room.

Intelligent Control System

MOBILE APP CONTROL SCREEN

Download the "Smart Life" APP from your mobile phone



Wireless Wall Switch and Remote Control

Each HE Series screen ships with both a wireless remote control and a wireless wall switch. The wireless wall switch provides easy installation of a switch to control the projector screen without the need for additional cabling.

Wi-Fi control

The intelligent control system also supports wireless IP control via the Smart Life app and a phone or tablet with additional voice control support via most smart speakers including Google Nest and Alexa.

Other Control Options

Standard control is via RF remote control and RF wall switch or Wi-Fi. Optional control components include IR remote control, 5V low voltage wired switches and 12V cables and connectors for serial (RS485) connection to control systems, PCs and projectors (via trigger port).

Housing and Mounting System

The Large HE Series are designed to mount on wall or on ceiling using appropriate fasteners or suspended using appropriate mounting hardware.

The white aluminium alloy housing is rectangular with a curved front face.

Warranty

This product comes with a two-year manufacturer's warranty.

Associated Products

SGSZTRIGGER	Trigger Cable suit IA/IT/HE series screen
SGSZSWITCH	Wired Switch for IA/IT/HE series screen
SGSZIRREMOTE	IR Remote control for IA/IT/HE Series
SGHELWARR1YR	Additional 1 year warranty for HE Series 3.5-4m screen (total 3 years)